

## Troubleshooting

Problem	Trace the problem	Solution
No light	Check the power	Connect the power cord properly Turn on the device
	Check the temperature	Check if it is installed according to the instructions
	Check the dimming	Unplug the light generator. Unplug the dimmer system from the driver. Turn on the power
Light switches on and off	Check the operating conditions of the light generator	Check if it is installed according to the instructions
	Check the active cooling system	Remove dirt and dust from the light generator

If problems are not solved using this guide, please contact RobLight A/S.



# RobLight

RobLight A/S, Nordhavnsvej 1A, DK-9900 Frederikshavn  
T: +45 9244 4888, E: info@rob-light.com  
www.rob-light.com

RobLight accepts no responsibility for possible errors in catalogues, brochures and other printed material.  
RobLight reserves the right to alter or discontinue its products without notice. © 2019 RobLight A/S

## FL 1010 B-1

### User manual

## Introduction

---

The RobLight FL 1010 B-1 light generator is designed for indoor use in dry locations with glass and PMMA fibre harness Ø9/Ø28 mm. It can be used in all installations set-ups, including closed compartments if limits for max ambient temperature are followed.

## Product overview/unboxing

---

1 FL 1010 B-1  
1 User manual

## Applies to :

---

0124 2018	FL 1010 B-1 3000K CRI 90+
0124 2718	FL 1010 B-1 3000K CRI 90+ Pot
0124 6718	FL 1010 B-1 3000K CRI 90+ Pot AUS
0124 2918	FL 1010 B-1 3000K CRI 90+ Zig
0124 2028	FL 1010 B-1 4000K CRI 90+
0124 2728	FL 1010 B-1 4000K CRI 90+ Pot

## Installation instructions

---

Follow the installation instructions to ensure

- Safe operation
- Full functionality
- Stated expected lifetime
- Uninterrupted illumination

## Application notes

---

The light generator is an electronic device and must be handled accordingly. The different components will have different factors influencing the practical lifetime. The most important factor for this system is the condition of the surrounding air (temperature and cleanliness). The data we have stated about or and the expected lifetime of the key components, are at the temperatures that the suppliers have performed during their standardized tests in clean environments.

The light generator is designed to run at max ambient temperature, but the longest usable operation is achieved with lower temperatures.

Although there is thermal protection built into this device, it is only a safety device and should not be used as a measurement device to test if the light generator is running at a tolerable surrounding temperature.

The polyconnector is the most stressed part of this system. Care should be taken to ensure that the fibre ends are 100% clean and free from dust and grease (fingerprint will do damage.). See [www.rob-light.com](http://www.rob-light.com) for recommendations to clean fibre ends.

Running the light generator at too high temperatures will not only risk damage to the light source but also to the fibre harness.

**KEEP COOL**

**CLEAN AIR**

## Maintenance, spare parts and repairs

---

The effectiveness of the active cooling device is greatly diminished if the cooling fins and the air intake is blocked or polluted with dust. This will reduce the expected lifetime of the product.

The dust must be removed on a regular basis. Interval depending on the environment.

A fine brush, vacuum cleaning or light compressed air can be used for the cleaning.

This light source is not supposed to be otherwise serviced, if used as recommended.

The fan can be replaced using standard tools. A replacement kit with guide is available.

If the product is not performing as specified, use the troubleshooting guide. If you need further assistance, please contact RobLight.

## Warning

---

This device has a built in high power phosphor converted blue led. The light source is grouped in Risk Group 2.

## Risk group 2

---



**CAUTION.**  
Possibly hazardous optical radiation emitted from this product. Do not stare at operating lamp. May be harmful to the eye.

Do not look into the light port when lit.

Beware of placing highly light absorbing material directly in front (Distance 0-1cm) of the port or a fibre. The extremely high intensity will increase the temperature in the material.

Using non RobLight harnesses in this light generator is at its own risk.

Ensure that the polyconnector is undamaged and clean before using the light generator in retrofit RobLight installations.

Beware that when the or a light generator is operated at max ambient temperature the surface temperature can exceed 75°C.

The light generator is only tested with RobLight standard polyconnector end.

## Warranty label

---

The warranty label is not to be broken under ANY circumstances. If broken the warranty is terminated.

## Technical data

### General

Light port	Ø9/Ø28 mm
Fibre type	PMMA or glass
Material	Aluminium, POM and other
Dimensions (L x H x W)	268 x 72 x 86mm
Weight (total)	1100g
Safety	CE, RoHS, WEEE

### Environmental

Protection rating	IP 20
Thermal protection	Automatic resettable
Cooling	Convection
Ambient temperature	-20 °C to 45 °C

### Driver/electrical

Driver	LED driver constant current
Supply voltage (mains)	100-240V 50/60Hz
Driver expected lifetime	50.000 hours (@TC = 65 °C)
Total power consumption	21W
Dimmer systems applicable	DALI 1-10V, PWM and PUSH (mains) and DMX

### Light source

Applied LED	Nichia COB
LED expected lifetime	>50.000 hours @Ta = 25 °C
Typical CCT	3000K or 4000K, 3SDMC
Typical Ra (CRI <sub>1-8</sub> )	93 (min. 90)

## Accessories / Spare part

	Part name	Description	Item no.
	CCT Filter A -500K	Will make the lighth warmer. Will not fade. No tools needed	0126 1000
	CCT Filter A -900K	Will make the light warmer. Will not fade. No tools needed	0126 1002
	CCT Filter A -1200K	Will make the light warmer. Will not fade. No tools needed	0126 1001
	Colour Filter, FL1000, yellow	Yellow colour filter. Glass. Will not fade. No tools needed	0126 1004
	Colour Filter, FL1000, green	Green colour filter. Glass. Will not fade. No tools needed	0126 1005
	Colour Filter, FL1000, blue	Blue colour filter. Glass. Will not fade. No tools needed	0126 1006
	Colour Filter, FL1000, red	Red colour filter. Glass. Will not fade. No tools needed.	0126 1007
	Colour Wheel kit	User attachable kit for make your fibres light in sparkling colours.	0126 6105
	Twinkling Wheel kit	User attachable kit to make your fibres twinkle.	0126 6205
	Dimmer 1-10V (potentiometer)	Attach it to the driver and the product can be dimmed	0126 5110
	Adapter Ø28/Ø9	If you want to change the light port from Ø28 to Ø9 mm.	7800 0130

## Installing accessories

The 1-10V dimmer potentiometer can be installed following this procedure.

Remove lid and wire fasternes from the driver  
 Place dimmer in 1-10V, brown wire in +  
 Place fasternes and lid again

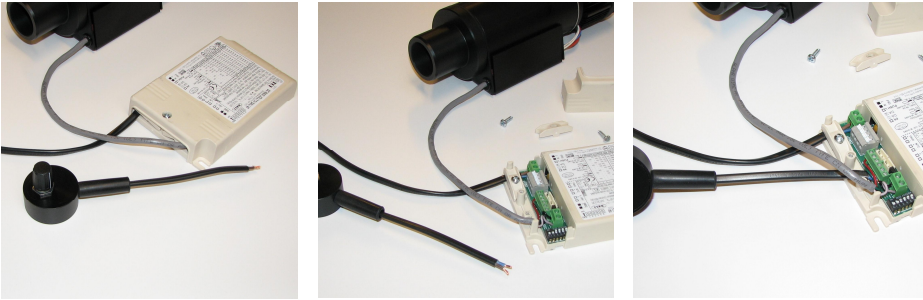

Network line

Wire from Dimmer 1-10V  
 Potentiometer

Wire from Light Generator

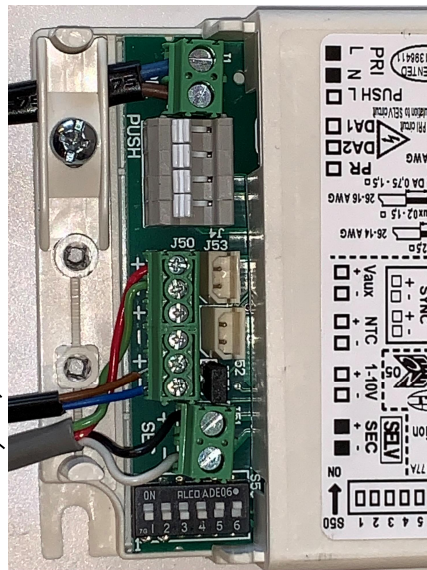

## Installation instructions

- Remove cap from the light port
- For use with  $\varnothing 9$  harness, mount the  $\varnothing 28 \rightarrow \varnothing 9$  harness adaptor on the common end Tighten the screw with the Allen key
- Insert the common end, fully in the light port
- Tighten the screw on the light port
- Ensure all installation and ventilation requirements are met
- Connect the supply cord to the mains

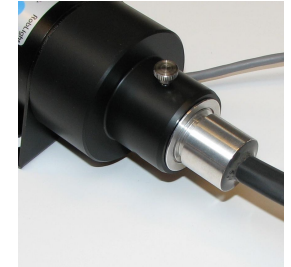

# RobLight

## Surface mounting

Attach to surface using two screws (not supplied) in the baseplate holes

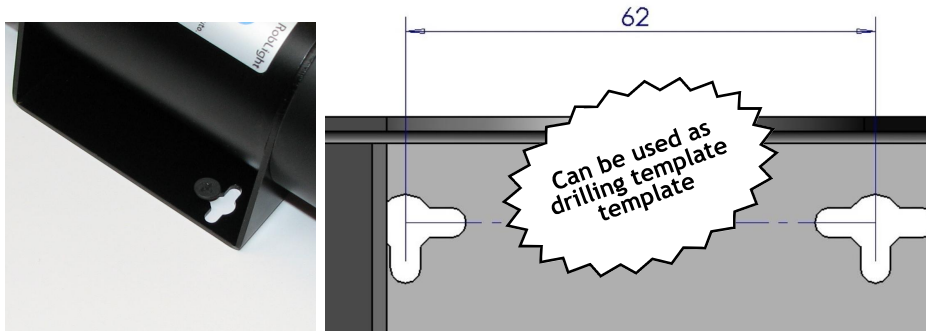

## Vertical mounting

This light generator should not be mounted with light port up. At high ambient temperature the operational lifetime of the internal components will be reduced.

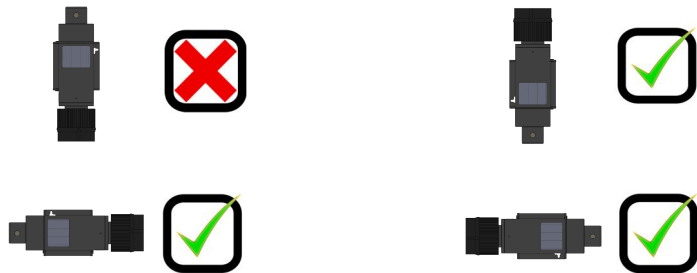

# RobLight

## Closed compartments

MAX AMBIENT TEMPERATURE 45°C.

Recommendations: (should always be tested in a mock up)  
Secure enough space to allow natural heat transmission through surfaces.  
Surfaces should not be insulated.  
Cooling air for the polyconnector can not be obstructed in any way, as it is essential to avoid damage to the harness.  
General minimum distance from the light generator to any enclosing surface 10 cm (excluded mounting surface).  
Ventilation holes per light generator with min. 20 cm<sup>2</sup> air inlet and min. 20 cm<sup>2</sup> air outlet.  
Beware of inlet and outlet ventilation holes opposite each other as shown on the drawing.  
Keep free from dust and polluted air.

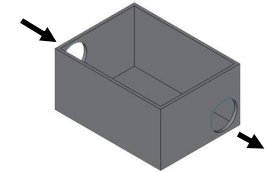

## Installing adjacent light generators

Recommendation:

Minimum 10 cm distance between adjacent light generators to ensure enough free cooling air.  
If multiple rows, use offset to avoid vertical rows. Minimal free distance between rows 15 cm.  
Max temperature has to be observed for all light generators measured at air inlet for each light generator.

MAX AMBIENT TEMPERATURE 45°C.

